



Capabilities

The following table outlines the capabilities of this GENIE device:

Type	GENIE
Version	2
Signals	
Pins	8
Analogue inputs	3
ADC resolution	8 bits
Digital inputs	1-4
Digital outputs	1-4
Features	
Parallel processing	Yes
Plug and play	Yes
Debug live	Yes
Device control	Yes
Sensor calibration	Yes
RTTTL music	Yes
16 channel MIDI music	No
Sound effects	No
PWM outputs	4
Servo motor control	4
Infra-red control	Yes
1-Wire® and I ² C	Yes
Ultrasonic sensing	Yes
Events and interrupts	Yes
1-second clock	Yes
Programming	
Program memory	1 K bytes
Variables	26 (A-Z)
Data (array) memory	16
EEPROM locations	16
Program start limit	2
Subroutine limit	No limit
Call stack limit	16
Electrical	
PICmicro® device	12F1822
Power supply	1.8-5.5V
Pin current limit	25mA
Total current limit	150mA

Component

The GENIE 08 microcontroller has 8 legs (known as pins) and these are used as follows (a simplified view is also shown):

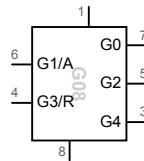
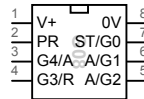

Pin	Description
1	Power supply voltage (1.8-5.5V only)
2	Programming input (PR)
3	Analogue input A4 or digital in/out G4
4	Digital input G3 or (optional) reset
5	Analogue input A2 or digital in/out G2
6	Analogue input A1 or digital in/out G1
7	Digital output G0 and Status output (ST)
8	Ground (zero volt) supply voltage

Circuit

The minimum circuit for a GENIE 08 is shown below. It includes a download socket and two resistors. See also 'Reset' overleaf.

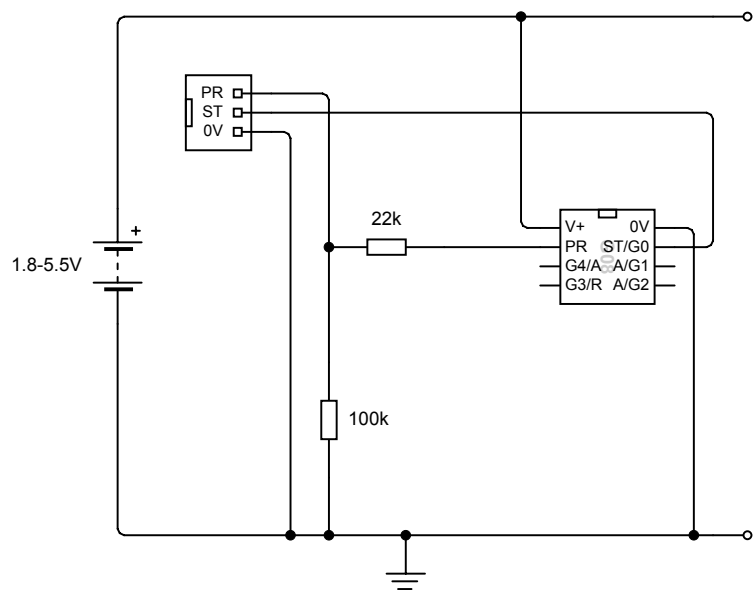



Notes

Reset

Pin 4 can be configured to be either an external reset pin or digital input G3. When configured as a reset pin, the microcontroller will reset whenever that pin goes low.

The recommend minimum circuit including a reset switch is shown on the right.

You can configure the reset pin by choosing the **Advanced** option in the **Program Settings** window and then clicking on **Reset**.

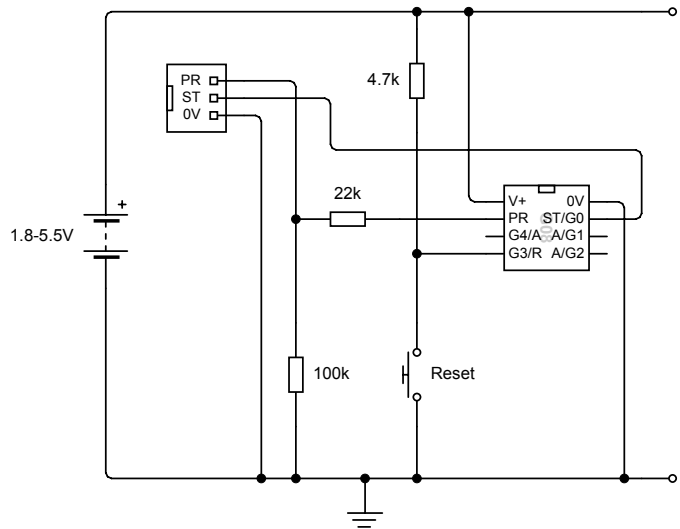

Turbo

The GENIE 08 microcontroller can operate at two different speeds: normal and turbo. In turbo mode, the internal oscillator within the microcontroller will be run at a faster (32 MHz rate), whereas in the normal speed mode, the oscillator will be at 16 MHz. Note that one consequence of running in turbo speed mode is that the minimum device supply voltage increases from 1.8V to 2.5V.

You can enable turbo speed mode by choosing the **Advanced** option in the **Program Settings** window and then clicking on **Turbo**.

